



# Enhancing Production Stability: The Role of AOI Across Flexible Packaging Production Processes

## Jim Gierke

*Author:*

*Michelle Sullivan, MBA*

*Dr. Schenk Industrial Surface Inspection*



# Industrial Surface Inspection



Production facility in Graefelfing





## Automated On-Line Inspection (AOI)

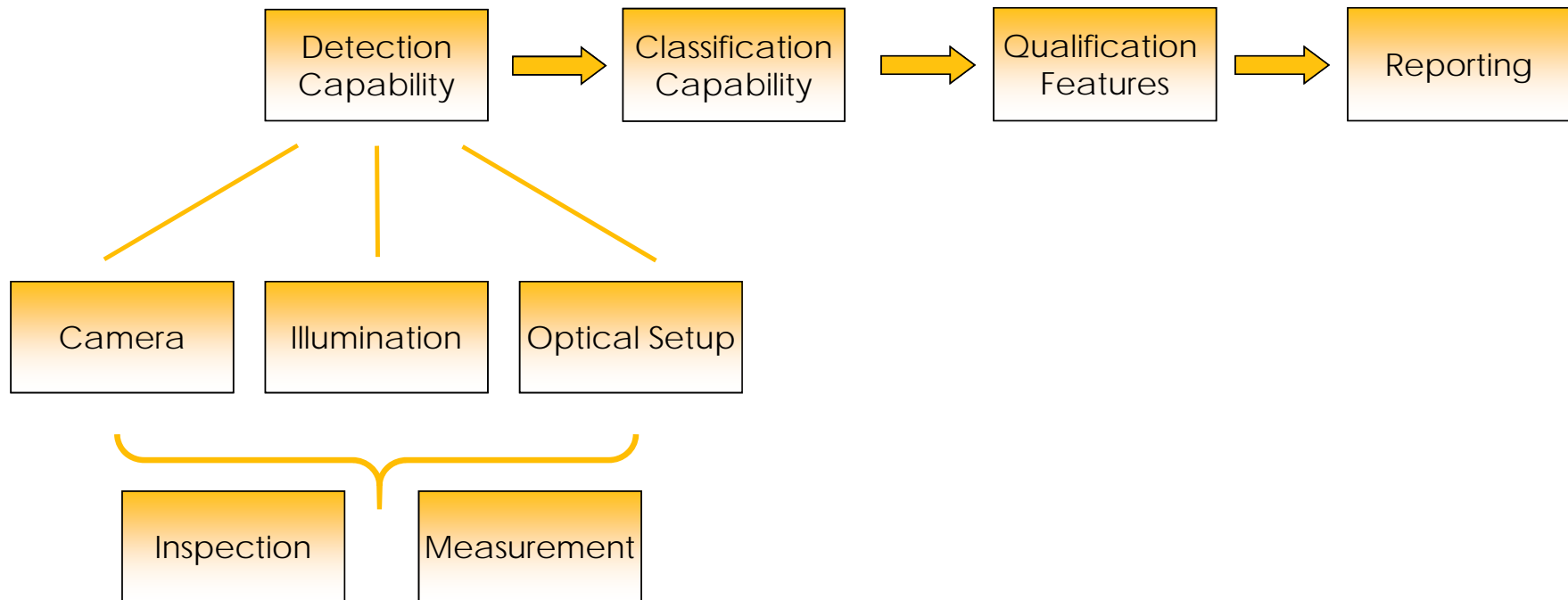



# 2024 FlexPack PLACE Conference

April 14-17, 2024 • San Diego, CA • Wyndham San Diego Bayside



# System Introduction



## AOI System Design Hardware





## System Configuration

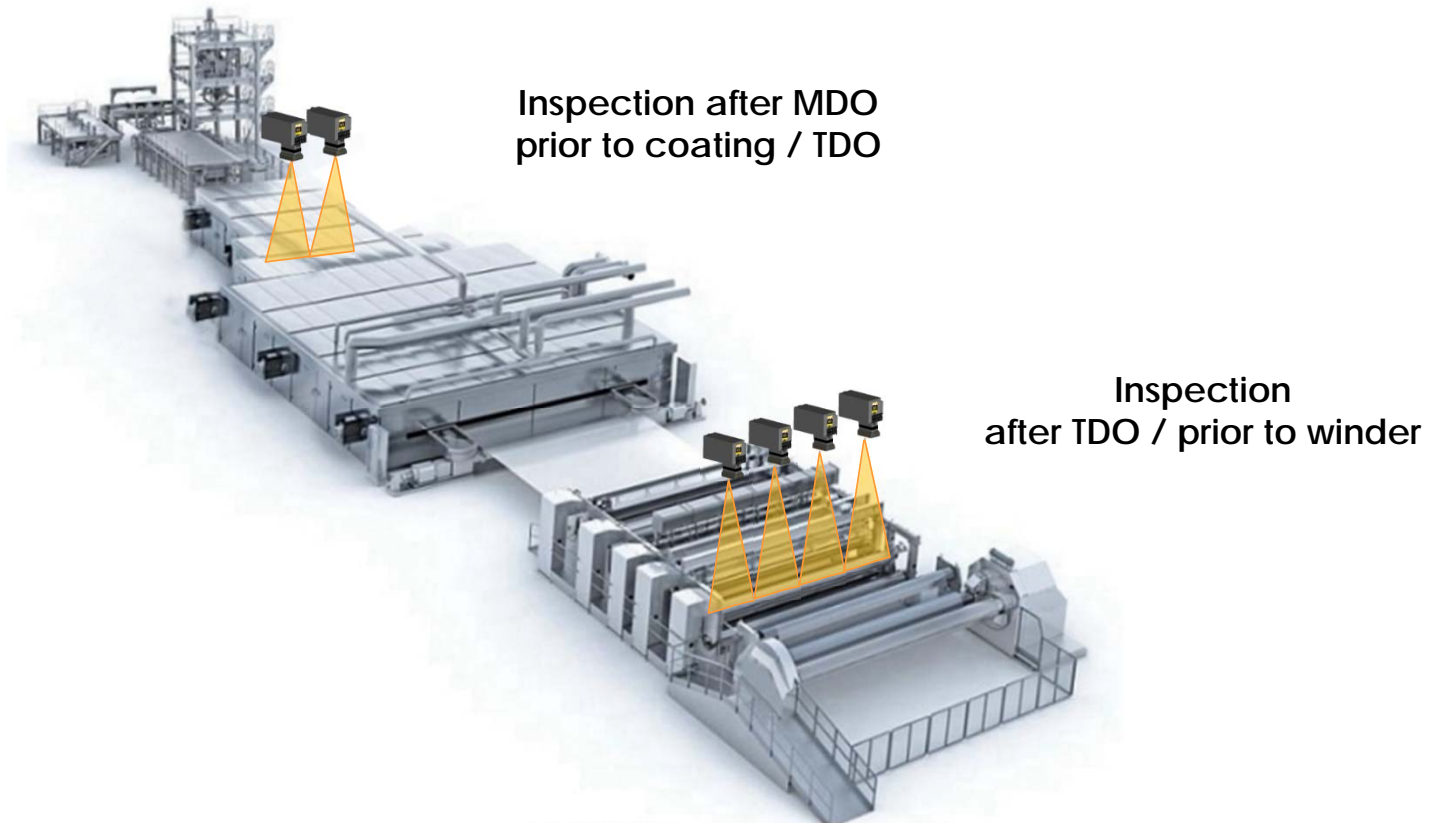



## How a line scan camera works?

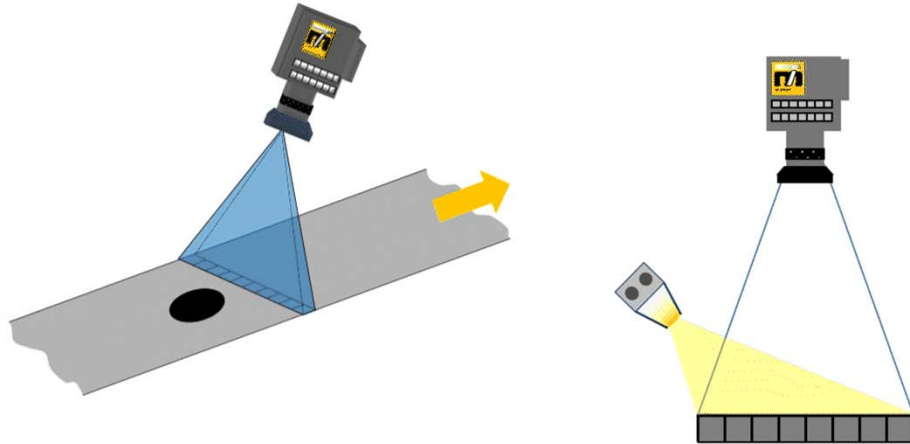



# Defects & Inhomogeneities in Base Film



## Flexible Packaging Inspection

- Typical tasks for flexible packaging film inspection include:
  - **Extruded / blown film inspection**
    - PE, PET, APET, EVA, PLA, POF, etc.)
  - **Extruded / cast film inspection**
    - (CPP, PA/PE, LDPE/LLDPE, etc.)
  - **(Bi-)Oriented film inspection**
    - (OPP/OPET, BOPP/BOPET, etc.)
  - **Coated / laminated /metallized film inspection**



## System Integration

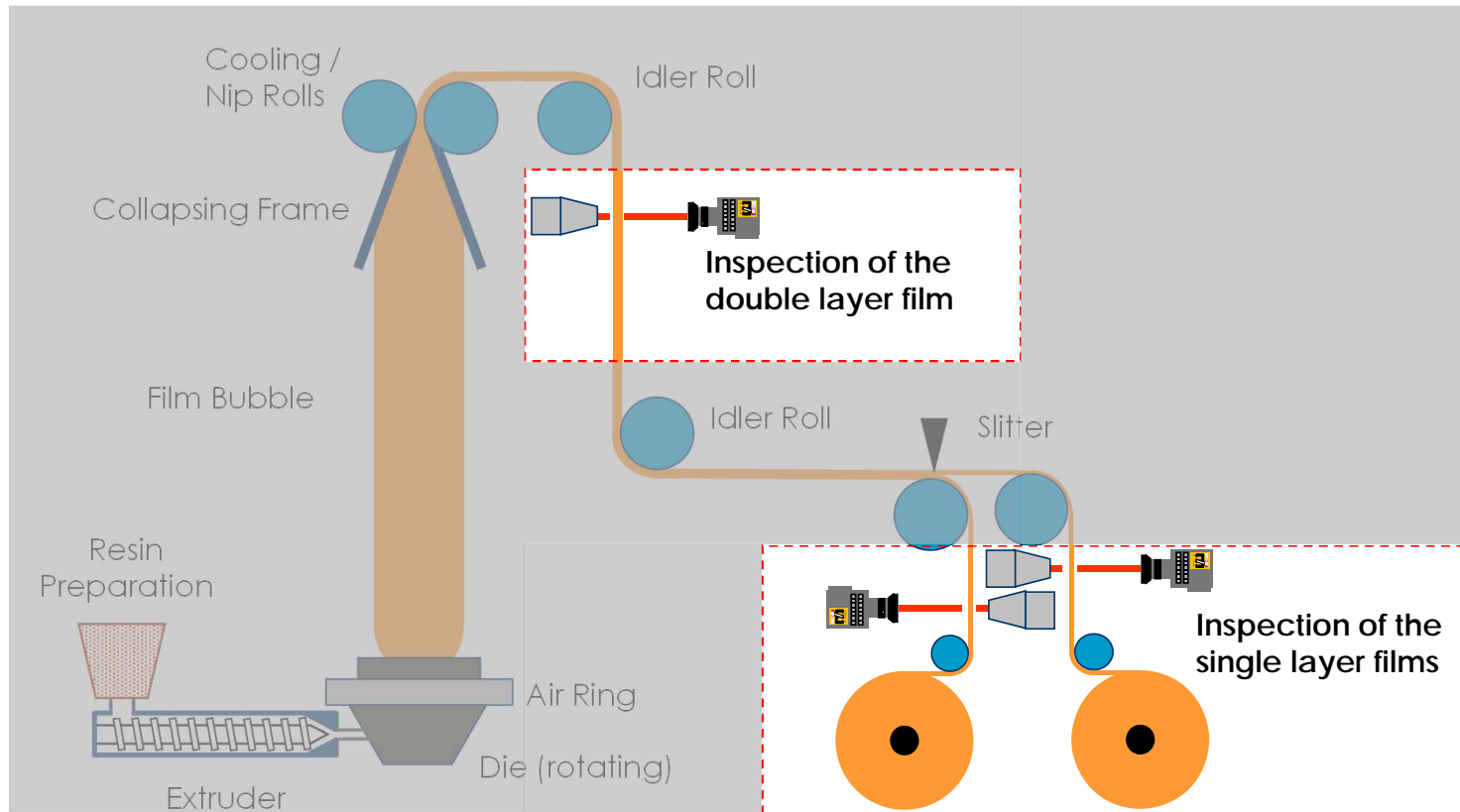



## Defects in Base Film

### Examples for local defects in base films

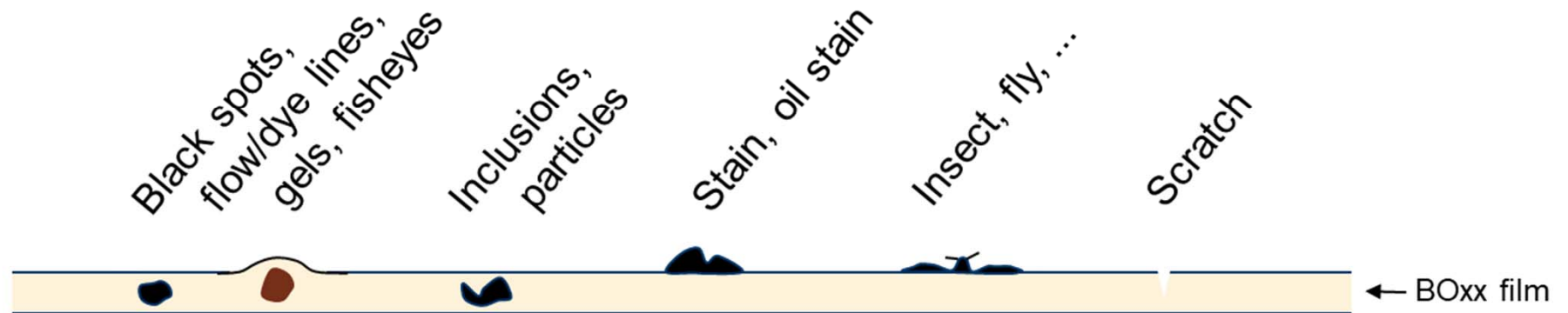



## Defect: Dark gel

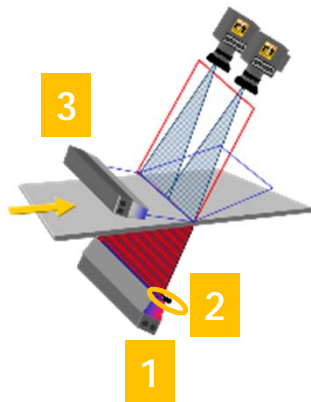

Transmission  
Brightfield **1**

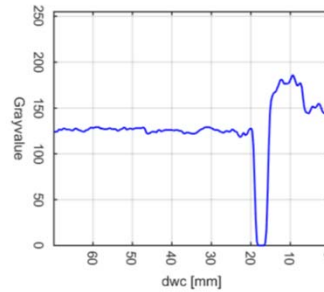
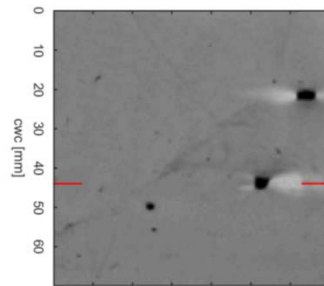

Transmission  
BF Knife-Edge **2**

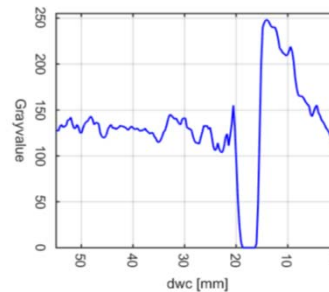
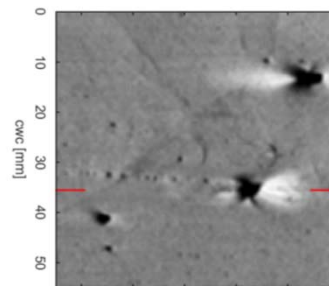

Reflection  
Darkfield **3**

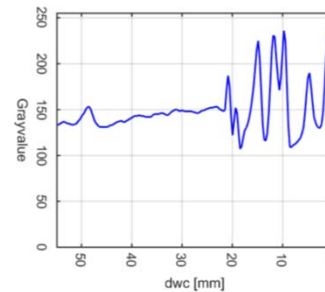
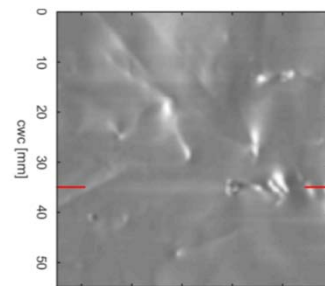

AWD17290-0



## Inhomogeneities in Base Film

### Examples for inhomogeneities in base films

Coating inhomogeneity



Variation in film surface topology (haze)

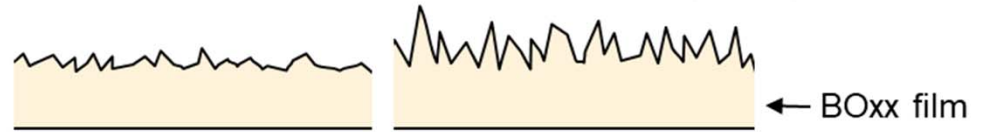



## Monitoring Film Thickness

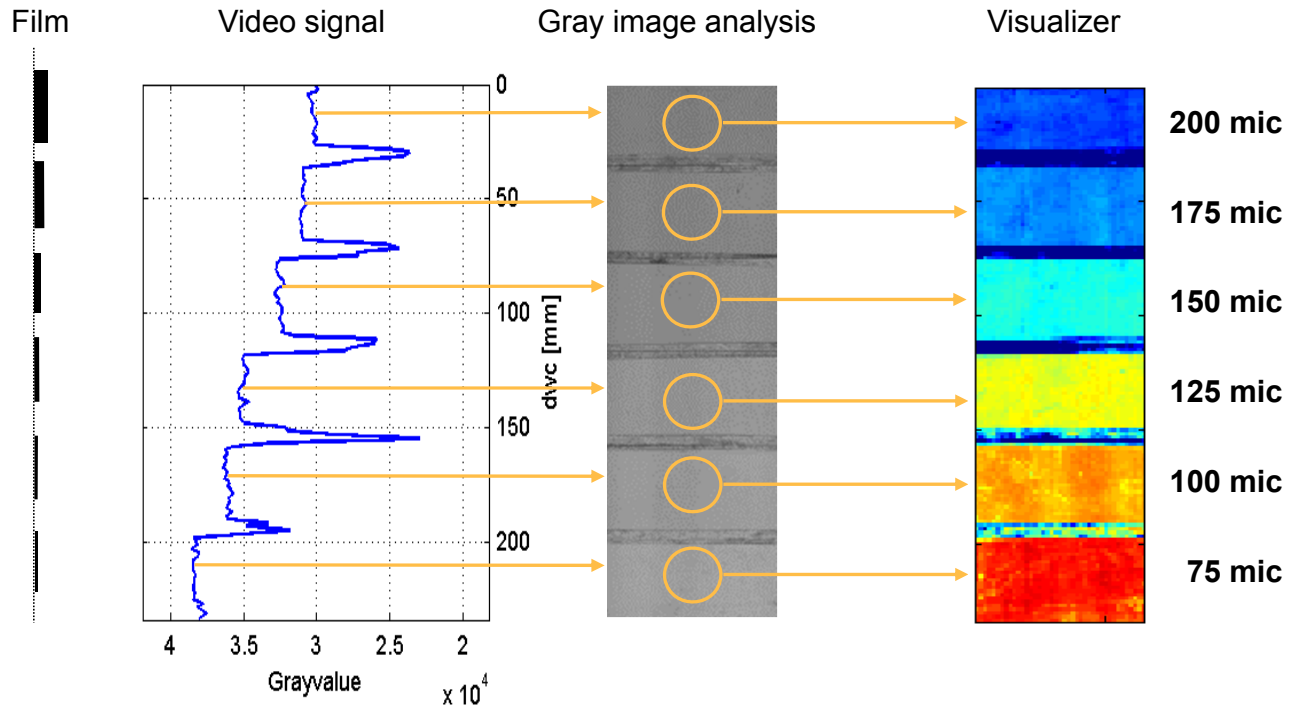



# Defects & Inhomogeneities After Converting



## Adhesive Coating, Label Stock + Tapes

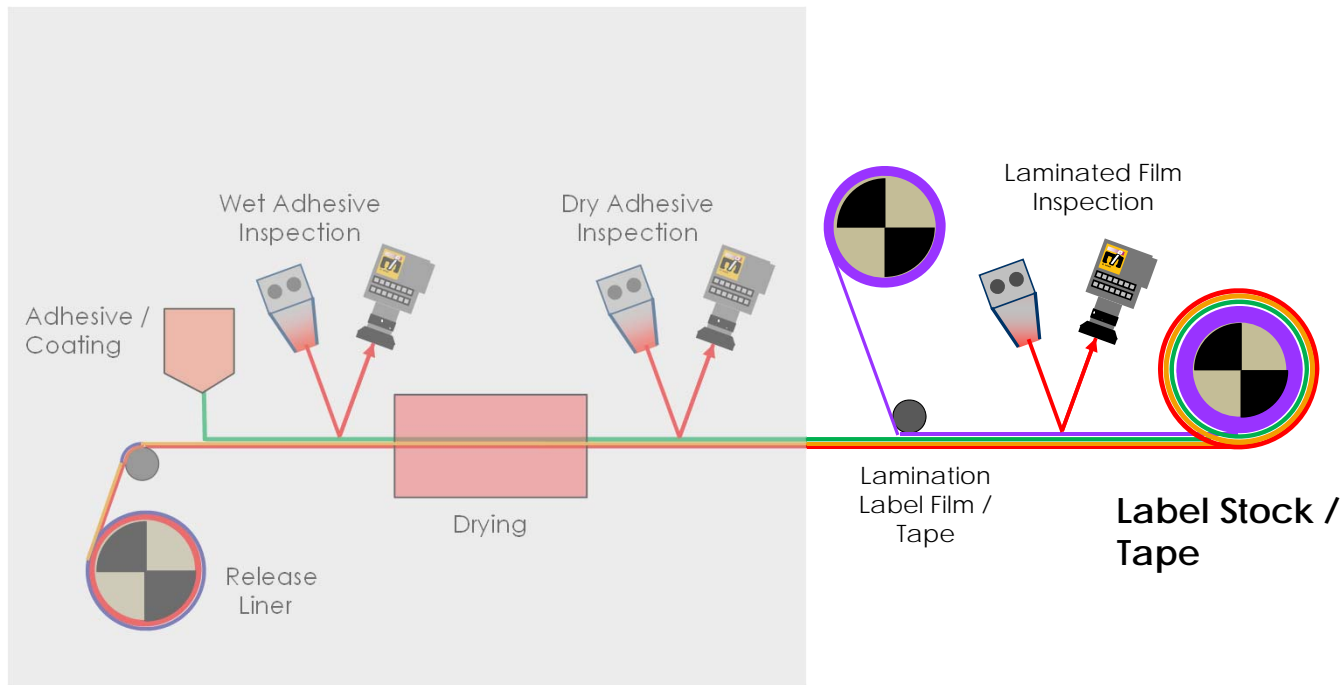



## Defect: wrinkle

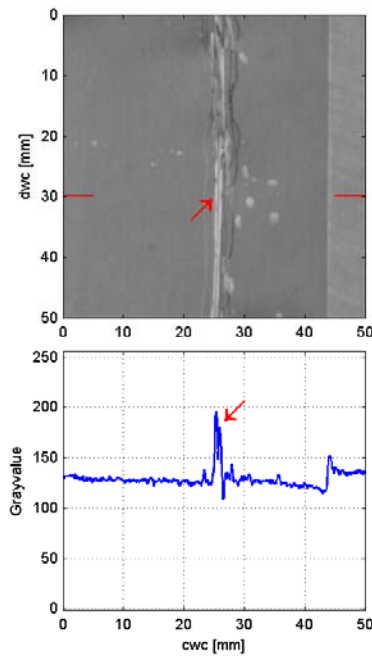
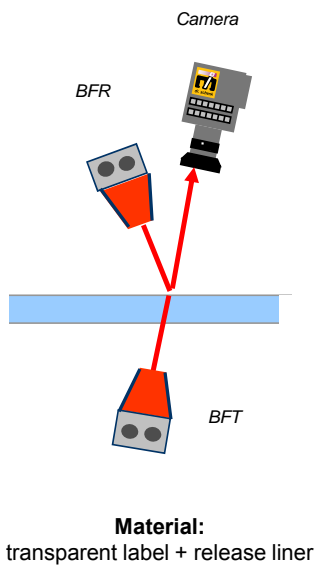

Brightfield Reflection

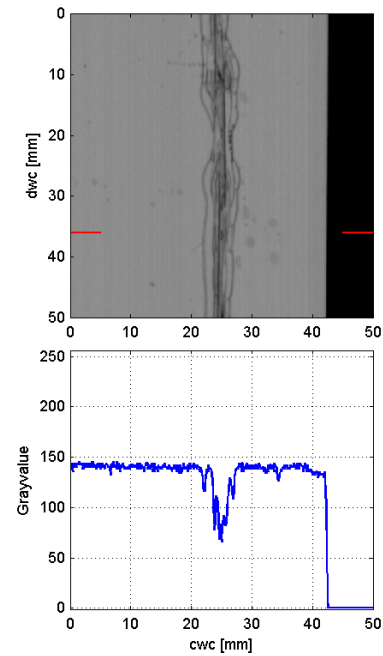

Brightfield Transmission



## Defect: void in adhesive coating

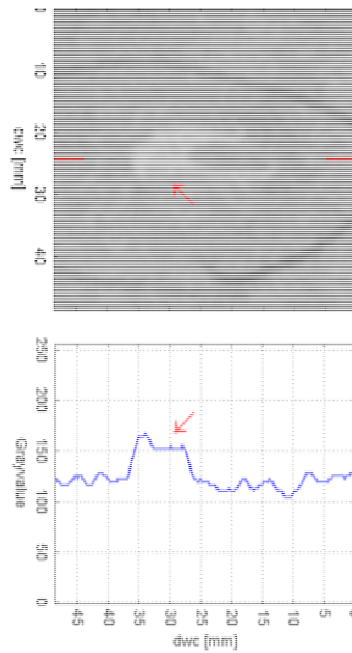
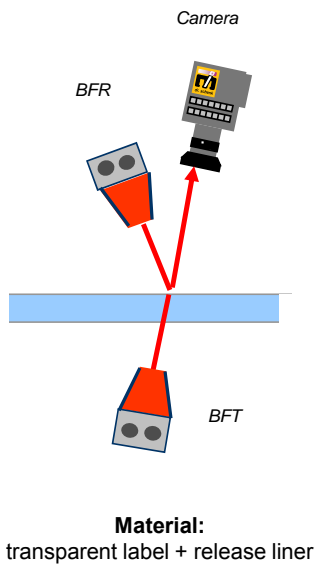

Brightfield Reflection

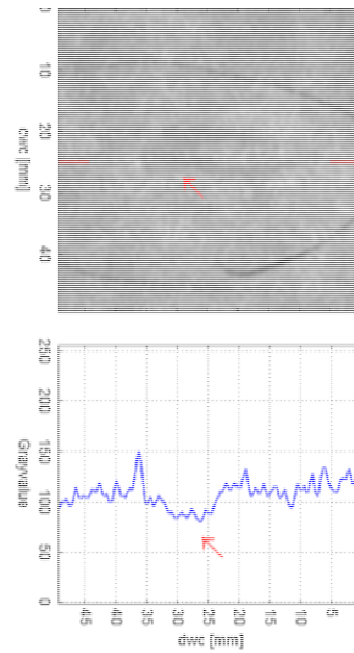

Brightfield Transmission



## Defect: bubble

**Material:**  
adhesive tape  
(with release liner)

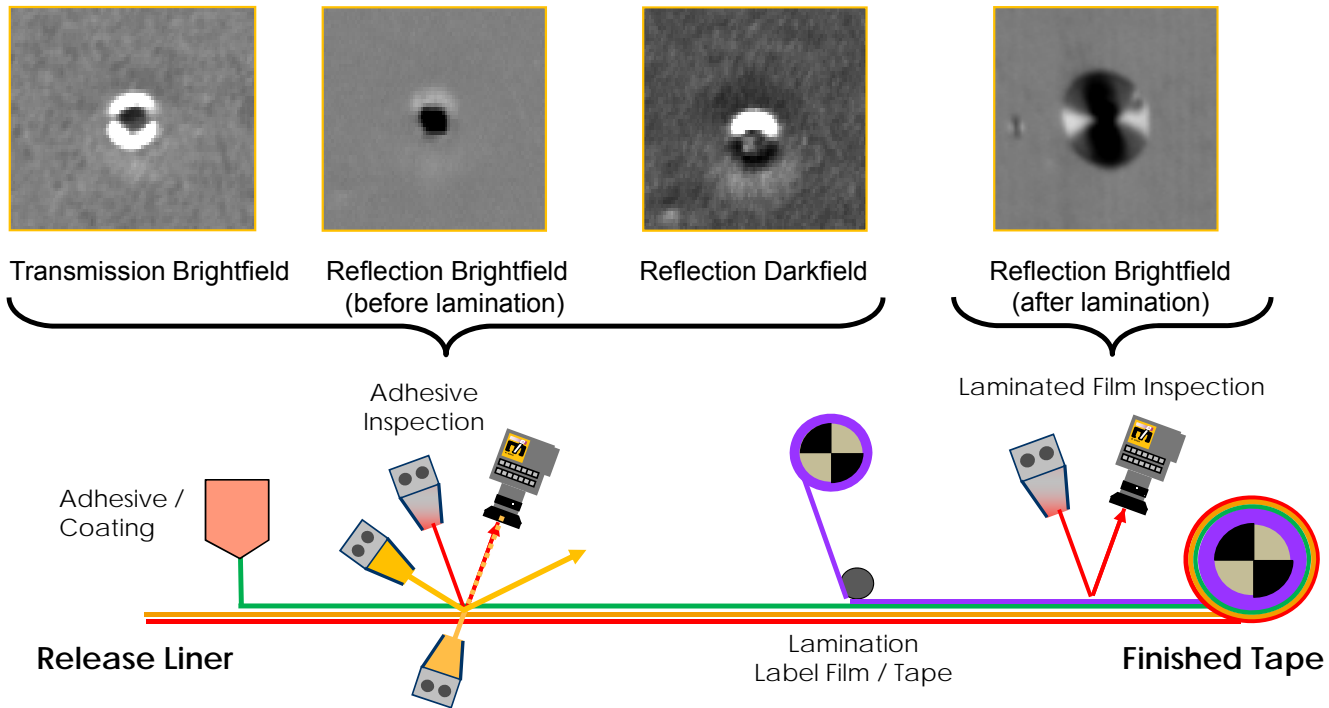



## Defect: missing coating

**Material:**  
adhesive tape  
(with release liner)

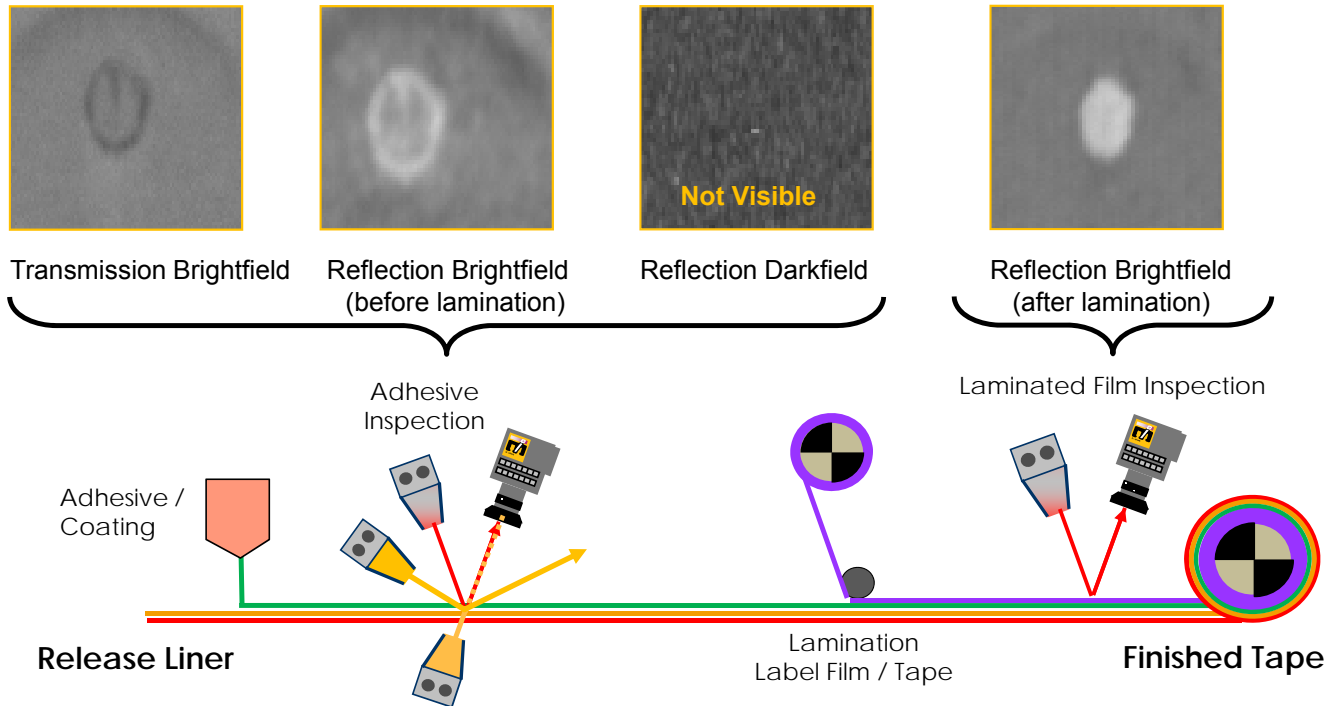



## Variation in coating layer thickness

PET with coating

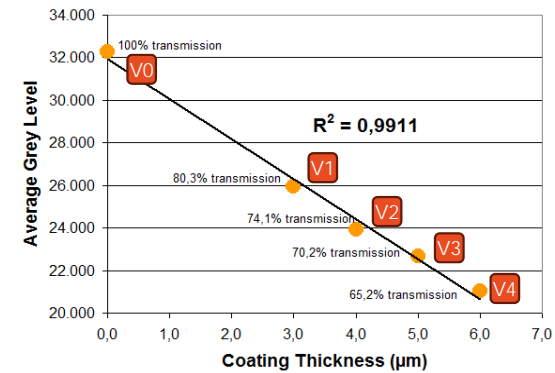
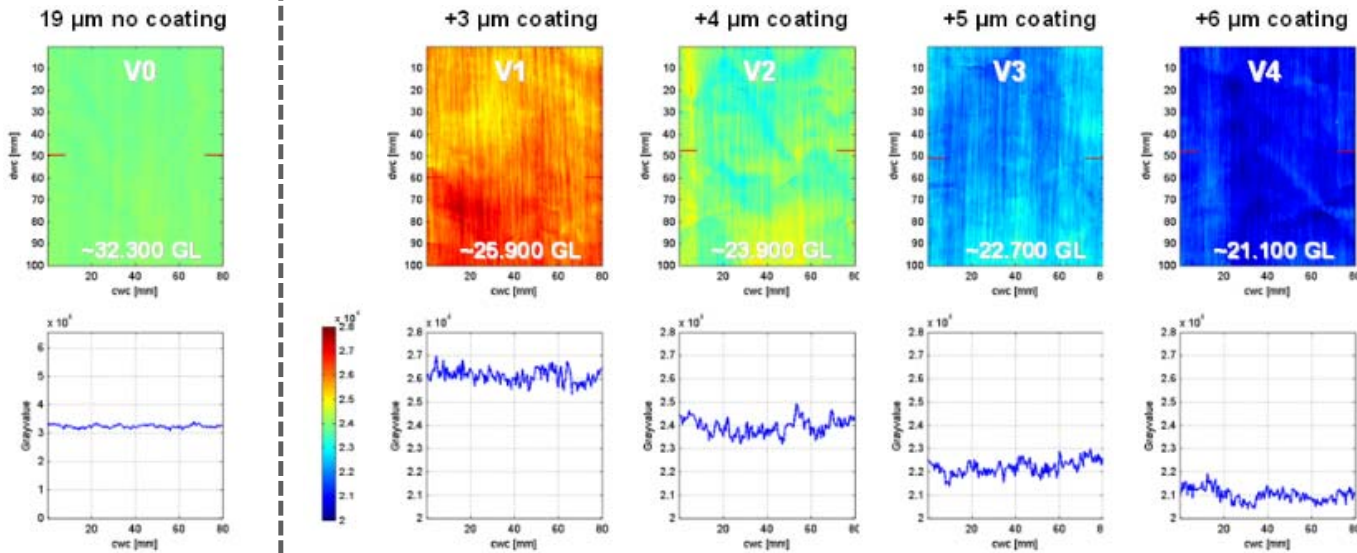



# 2024 FlexPack PLACE Conference

April 14-17, 2024 • San Diego, CA • Wyndham San Diego Bayside



# Software



## Software Clients

### Visualization Client

VIZ

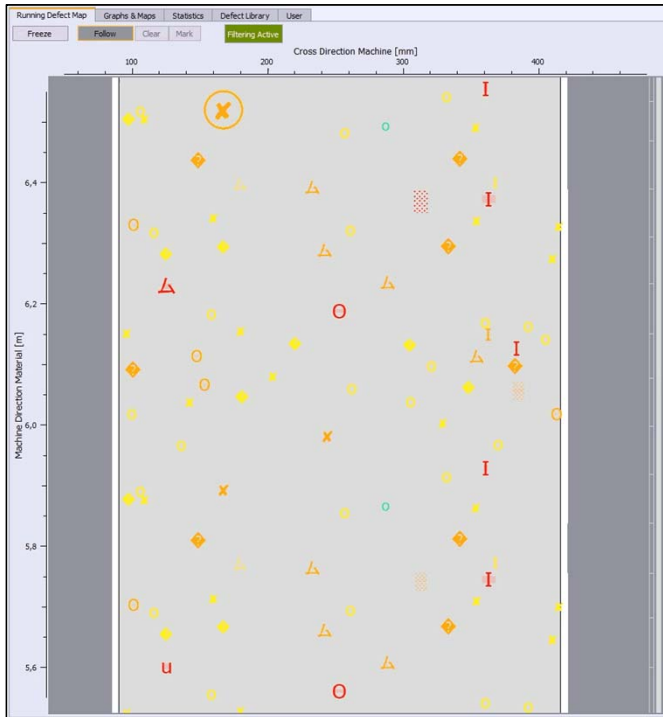

### Production History Client

PHC

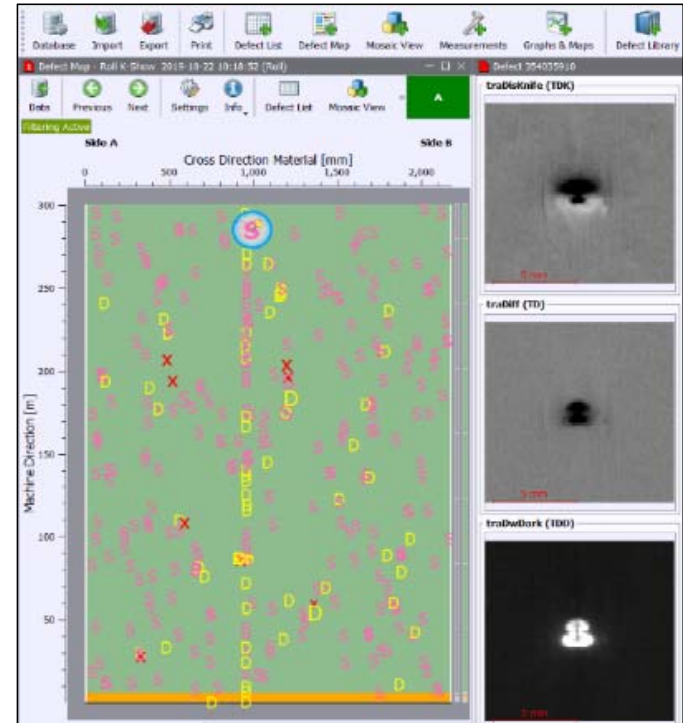



# Training a Classification Model

Unknown data

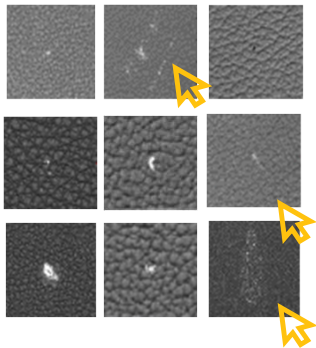

Target classes

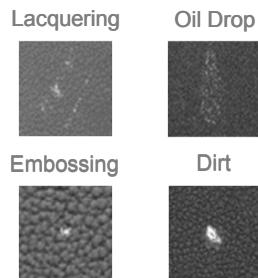

Defect library



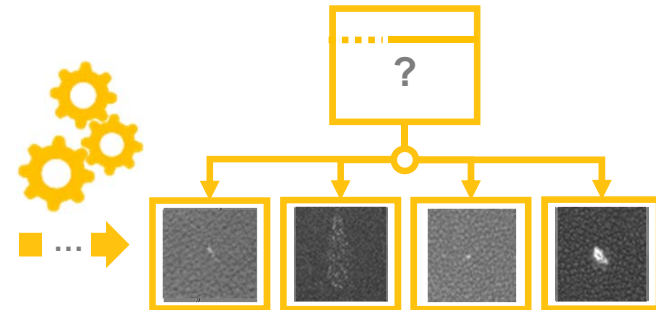

Classification model



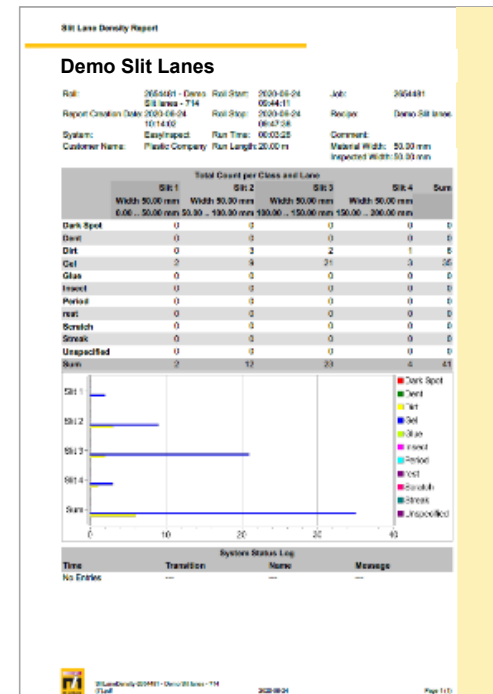
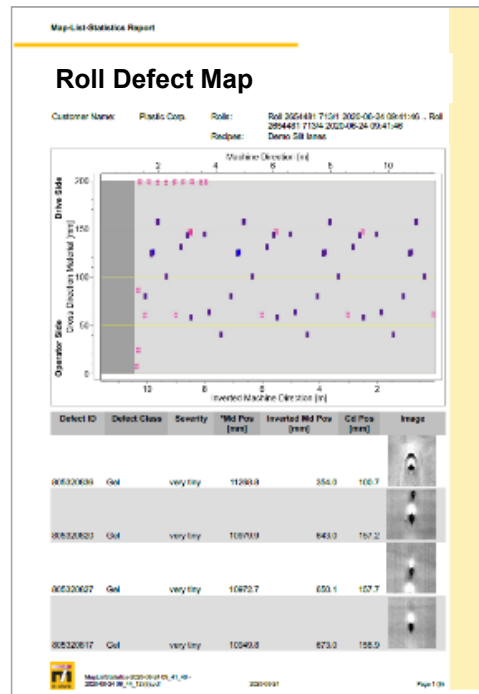
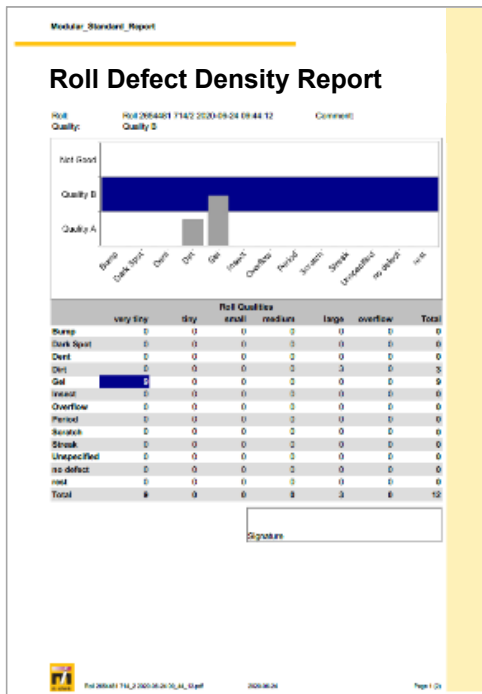

# Roll Reports



# 2024 FlexPack PLACE Conference

April 14-17, 2024 • San Diego, CA • Wyndham San Diego Bayside



## Any Questions ?...

### Dr. Schenk Industrial Surface Inspection

Jim Gierke

[James.Gierke@drschenk.com](mailto:James.Gierke@drschenk.com) | phone: (651) 286-8655

[www.schenkvision.com](http://www.schenkvision.com)

