

**NOTICE: This document is a TAPPI Standard in ballot. Although available for public viewing, it is still under TAPPI's copyright and may not be reproduced or distributed without permission of TAPPI. This document is current under review to be maintained as a TAPPI Standard.**

WI 250809.07

T 248

BALLOT NO. 02 - SARG

DRAFT NO. 01

DATE June 9, 2026

WORKING GROUP  
CHAIR N/A

SUBJECT  
CATEGORY Pulp Properties

RELATED  
METHODS See "Additional Information"

**CAUTION:**

This Test Method may include safety precautions which are believed to be appropriate at the time of publication of the method. The intent of these is to alert the user of the method to safety issues related to such use. The user is responsible for determining that the safety precautions are complete and are appropriate to their use of the method, and for ensuring that suitable safety practices have not changed since publication of the method. This method may require the use, disposal, or both, of chemicals which may present serious health hazards to humans. Procedures for the handling of such substances are set forth on Safety Data Sheets which must be developed by all manufacturers and importers of potentially hazardous chemicals and maintained by all distributors of potentially hazardous chemicals. Prior to the use of this method, the user must determine whether any of the chemicals to be used or disposed of are potentially hazardous and, if so, must follow strictly the procedures specified by both the manufacturer, as well as local, state, and federal authorities for safe use and disposal of these chemicals.

## **Laboratory Beating of Pulp (PFI Mill Method)** *(Five-year review of Standard Practice T 248 sp-21)*

### **1. Scope**

1.1 This standard practice describes the processing of pulp by means of the PFI mill (*I*) to evaluate pulp quality for papermaking.

1.2 In principle, the standard practice applies to all types of pulp; in practice, the method may not give satisfactory results with certain very long-fiber pulps such as cotton.

1.3 The standard practice is suited to processing small quantities of test specimens that are too small for processing in the Valley beater, as described in TAPPI T 200 "Laboratory Processing of Pulp (Beater Method)."

### **2. Applicable documents**

- 2.1 TAPPI T 205 "Forming Handsheets for Physical Tests of Pulp."
- 2.2 TAPPI T 220 "Physical Testing of Pulp Handsheets."
- 2.3 TAPPI T 227 "Freeness of Pulp."

### 3. Summary

A measured amount of pulp at specified concentration is beaten between a roll with bars and a smooth-walled beater housing, both rotating in the same direction but at different peripheral speeds. Beating action is achieved through the differential rotational action and the application of a specified load between the beater roll and housing for a specified number of revolutions.

### 4. Significance

While no one laboratory method of beating pulp can simulate commercial refining practices, the PFI mill method is accepted by some for use on small sample sizes. Physical testing of laboratory-beaten pulps may provide data that aid in determining the ultimate performance of pulp when converted to paper.

### 5. Definition

Beating is defined as the mechanical action applied to pulp between two parallel surfaces, under constant loading, moving differentially relative to one another. The PFI mill achieves this action by having the inner roll and outer casing rotate under constant load, in the same direction, but with differing peripheral speeds.

### 6. Apparatus

6.1 *PFI mill*<sup>1</sup> (see Figs. 1 and 2)<sup>2</sup>, consisting of the following:

**NOTE 1:** The mill should be installed and leveled per manufacturer's instructions.

6.1.1 A stainless steel roll with chiseled bars and a stainless steel housing in the form of a container with a smooth cylindrical internal wall, into which the pulp sample is placed. Both housing and roll rotate on independent vertical axes in the same direction, the roll rotating faster than the housing. The number of revolutions of the roll is indicated by a counter.

**NOTE 2:** The first mills manufactured had beating elements made of bronze; however, the surfaces were conditioned to give the same results of beating as elements made of stainless steel.

---

<sup>1</sup>Names of suppliers of testing equipment and materials for this method may be found on the Test Equipment Supplier's list in the set of TAPPI Test Methods or may be available from the TAPPI Quality and Standards Department.

<sup>2</sup>Figures 1 and 2 are reproduced with permission of PAPTAC.

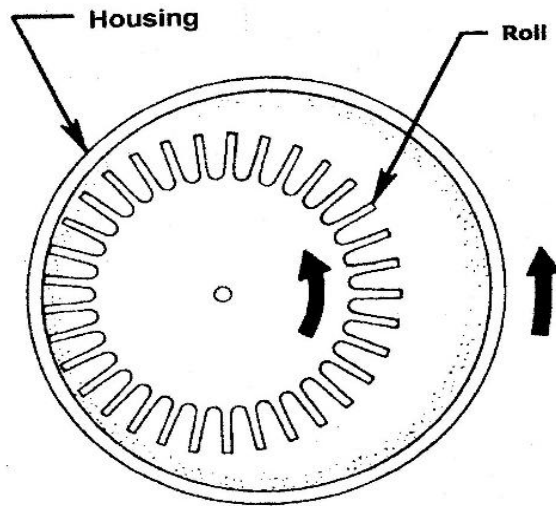

Fig. 1. The PFI laboratory beater elements.

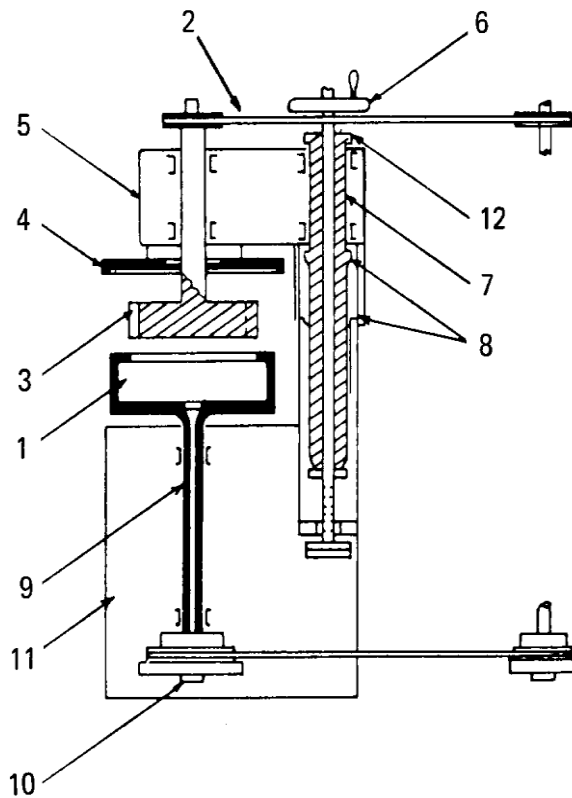

Fig. 2. The PFI laboratory beater (vertical section sketch). 1 = housing; 2 = timing belt; 3 = roll; 4 = cover; 5 = roll lever arm; 6 = handwheel; 7 = pillar; 8 = stop peg; 9 = shaft channel; 10 = screw nut; 11 = frame; 12 = cantilever.

6.1.2 The roll has 33 bars, each  $50 \text{ mm} \pm 0.5 \text{ mm}$  long and  $5 \text{ mm} \pm 0.2 \text{ mm}$  wide. The bars are spaced uniformly about the circumference of the roll and are parallel to the roll axis. The diameter of the roll, measured across the bars, is  $200 \text{ mm} \pm 0.5 \text{ mm}$ . Depth of the cavities between the bars is 30 mm. The rotation speed of the roll during beating (loaded) must not decrease by more than 50 rpm from the measured unloaded roll speed. The roll is driven by a 750-W (1.0-hp) motor. Rotation speed of the roll, unloaded, is  $1460 \pm 10 \text{ rpm}$ . The number of revolutions of the roll is indicated by a counter.

6.1.3 The beater housing has an internal diameter of  $250 \text{ mm} \pm 0.5 \text{ mm}$  and is driven by a 375-W (0.5-hp) motor. The rotational speed of the housing unloaded is  $720 \pm 20 \text{ rpm}$ . During beating (loaded) the rotational speed of the housing must not increase by more than 25 rpm from the measured unloaded housing speed. The prescribed difference in peripheral speed between the beating elements is  $6.0 \pm 0.3 \text{ m/s}$  with the roll having rotational speed of 1460 rpm (unloaded).

6.1.4 Both the roll and the housing are driven by means of timing belts. The change in rotational speed of either element during beating is not to exceed 66 rpm.

6.1.5 The beating pressure is obtained by means of a load applied by a lever that presses the roll against the wall of the beater housing. Force applied is to be 3332 N/m of bar length, 17 kg total bar load.

**NOTE 3:** For very easily beaten pulps (e.g., hardwood sulfites) a smaller load, which gives a beating load of only 1765 N/m of bar length, 9 kg total bar load, may be applied, provided this is noted in the test report.

6.1.6 The mill is also equipped with a device which includes a Vernier adjusting screw regulating the distance between the roll and housing when grinding-in and conditioning the mill.

6.2 *Disintegrator*, as described in T 205.

6.3 *Water*. ASTM Type II water is preferred for the beating run and associated freeness determinations. For repeatable, reproducible results, and in all laboratory comparisons, distilled or deionized water must be used for both beating and freeness testing. Tap water will significantly affect the freeness values, beating times and test data. The relevant properties of ASTM Type II water (3) are as follows:

Total organic carbon (TOC) matter, max:	50 $\mu\text{g/L}$
Electrical conductivity, max:	1.0 $\mu\text{S/cm}$ at 298K (25°C)
Electrical resistivity, min:	1.0 $\text{M}\Omega\text{-cm}$ at 298 K (25°C)
Sodium, max:	5 $\mu\text{g/L}$
Chlorides, max:	5 $\mu\text{g/L}$
Total silica, max:	3 $\mu\text{g/L}$

## 7. Calibration and maintenance

### 7.1 Calibration

7.1.1 The PFI beater is a rugged machine requiring calibration only after major changes have occurred in the beater roll and/or housing. Clear all pulp to be processed of hard particles that may damage the roll surfaces and beater housing. If beating surfaces have been damaged so that the mill gives incorrect results for reference pulps, grind and condition the beating surfaces as follows.

7.1.2 Reverse the direction of rotation of the motor driving the beater housing.

7.1.3 Set the gap micrometer so there is a 0.5 mm (0.02 in.) gap between the beating elements (1 scale division equals 0.05 mm or 0.002 in.).

7.1.4 Load the beater housing with 15.0 g of silicon carbide grinding powder No. 180 suspended in 50 mL water soluble cutting oil diluted with 50 mL of water at  $26 \pm 1^\circ\text{C}$ . Ensure that the silicon carbide powder, the cutting oil and the water are well mixed before the beater housing is set in motion.

7.1.5 With the beater roll raised and locked aside, start the beater housing so that the grinding powder suspension is flung against the housing. Allow the beater housing to run for 5 minutes, and then stop the motor. Ensure the grinding powder suspension is uniform and free of oil globules. If oil globules are present, disperse these with a finger, then run the housing for a further 3 minutes or until oil globules are no longer present. Stop the housing. Ensure the cover is in its position in the bracket and insert the roll in the housing. Press the cover into position. Start the beater housing motor and allow it to run for an additional 3 minutes. Then start the beater roll motor and gradually apply the full beating load and let the PFI mill run for 5 seconds and then remove the bearing

load and allow the beater roll and housing to rotate for 1 minute. Repeat this procedure three or four times to ensure the grinding powder is uniformly dispersed around and up the beater housing wall.

7.1.6 Upon completion of 7.1.5, apply the full load again and carefully reduce the gap between the beating elements by means of the Vernier screw until a grinding sound is heard. Run the mill until the sound has diminished significantly. Then reduce the gap further but not exceeding one-half scale division (0.03 mm or 0.001 in.). Continue grinding step by step in this manner until the damage is repaired.

7.1.7 Clean the beating elements and cover with soap and water. Ensure no silicon carbide powder remains.

7.1.8 After this rough grinding, perform a fine grinding with silicon carbide powder No. 280 as described in 7.1.4 and 7.1.5 until the beating surface is smooth and uniform. Do not exceed 3000 revolutions or have a grinding gap of less than 0.2 mm.

7.1.9 Clean the beater as outlined in 7.1.7.

7.1.10 Carefully, without rounding, remove with a fine flat honing stone any rough edges that have appeared on the trailing edges of the bars. Do not use a file. Finish honing with a neoprene polishing stone. Clean the roll bars thoroughly to remove filings.

7.1.11 Restore the rotation of the beater housing to the counter-clockwise direction. Set the distance between the roll and housing to 2 mm (0.079 in.) with a gap micrometer. Polish the beating surfaces by beating 24 g o.d. of bleached softwood kraft or bleached softwood sulfite to which 15 g of silicone carbide powder No. 280 has been mixed. The degree of grinding may be checked by placing writing paper and carbon paper between the roll and housing, applying light pressure, and rotating the elements manually.

7.1.12 Upon completion of the conditioning cycle, clean the housing and roll thoroughly. Disengage the gap micrometer and set to zero clearance.

7.1.13 Stabilize the beating surfaces by making a series of normal pulp beatings totaling between 50,000 and 100,000 roll revolutions. To prevent lignin buildup on the beating surfaces, do not beat samples to below a freeness of 300 ml CSF in the stabilization process. Verify the final evaluation of the degree of conditioning by beating a previously standardized pulp in accordance with Section 9.

## 7.2 Maintenance

7.2.1 The precision of the results depends to a great extent on the cleanliness of the apparatus. Remove rosin deposits. Wash with a filtered solution of sodium pyrophosphate or other resin dispersant at 70 to 80°C.

7.2.2 Timing belt drives are recommended to ensure correct speed levels of housing and beater roll. For beaters not so equipped, check that the belts are not slipping when pressure is applied (6.1.5).

7.2.3 Check that all parts move freely so the entire applied load is transmitted as beating pressure.

7.2.4 Under normal conditions beating efficiency of the mill should remain constant. Carry out preventative maintenance every 10,000 beatings by stripping the machine and examining the bearings for wear, replacing them as necessary. Excessive vibration is caused by wear of the spur tooth sectors through which beating pressure is applied to the roll assembly. Replace worn sectors.

7.2.5 Inspect the beating surfaces for damage and check regularly that the cover fits properly on the housing.

7.2.6 Check the condition of the mill from time to time by beating and testing a pulp which is kept for reference purposes and has been stored sufficiently long enough to avoid further changes in its properties. The reference pulp should preferably be of the same type as that normally beaten in the mill. If the reference pulp is purchased from a commercial source, take care to closely follow the exact referenced procedures provided with the pulp.

**NOTE 4:** Avoid beating of pulp which contains sand, grit or other materials which could change the surface conditions of the beating elements. If surface damage occurs it is necessary to repolish the surfaces.

**NOTE 5:** For multiple beating runs to different freeness values on the same pulp, combine the disintegrated pulps into one large sample. Stir thoroughly and take out 2000 mL sample for each beating run and proceed to thickening (Section 9.2). This should be done to reduce the variability of the sample due to processing and sampling.

## 8. Sampling and test specimens

From a representative sample of the pulp, obtain a specimen weighing  $24.0 \pm 0.25$  g oven dry (o.d.) for each beating run. When sampling dry lapped pulp, avoid cut edges and do not cut the pulp. With dried pulps, soak the specimen

in 500 mL of distilled water at room temperature for a minimum of 4 h. Tear the soaked pulp into pieces approximately 25 × 25 mm (approximately 1 × 1 in.). It is essential that the pulp be thoroughly softened by soaking to ensure that preliminary disintegration results in the least possible beating effect. Wet pulps may be disintegrated without soaking.

**NOTE 6:** If a different sample weight is used, such as 30 g o.d., report this with test results.

## 9. Procedure

### 9.1 *Disintegration*

9.1.1 Transfer the wet pulp and water used for soaking to the disintegrator. Add distilled water at  $20 \pm 5^\circ\text{C}$  to give a total volume of  $2000 \pm 25$  mL; the consistency will then be 1.2%. Set the revolution counter to 3000 (30,000 revs = 10 minutes) for an initial consistency of 20% or more. For consistencies less than 20%, set revolution counter to 15000 (15,000 revs = 5 minutes). One unit on the counter equals 10 revolutions of the roll.

9.1.2 Ensure that the pulp is completely disintegrated. Pulps difficult to disintegrate, such as unbleached sulfate, may require longer disintegration than that specified in 9.1.1. Report any departure from recommended procedures.

### 9.2 *Thickening*

9.2.1 After disintegration, drain the pulp suspension on a Büchner funnel using a coarse filter paper to approximately 20% consistency. To avoid loss of fines, refilter the filtrate through the fiber mat until clear. Weigh the thickened pad and determine the amount of distilled water at  $23 \pm 2^\circ\text{C}$  to dilute the pulp to a total mass of  $240 \pm 0.5$  g, corresponding to a 10% stock consistency. Peel the pulp from the filter paper and place in a 400-mL beaker and wash the filter paper with the distilled water measured out above.

### 9.3 *Beating*

9.3.1 Adjust the temperature of the PFI mill to  $23 \pm 2^\circ\text{C}$  (see Note 7) before charging and, if necessary, that of the pulp such that the mean temperature does not exceed  $23 \pm 2^\circ\text{C}$  during beating.

**NOTE 7:** When necessary for reasons of climatic conditions, a temperature of  $25 \pm 5^\circ\text{C}$  may be used provided this is reported with the test results.

9.3.2 Make sure the Vernier adjusting screw is set to give a beating gap of 0.2 mm between the roll and housing (see Appendix A).

**CAUTION:** Do not operate PFI mill without pulp in the bowl when the Vernier adjusting screw is not set to a fixed minimum distance. Severe damage to the roll and housing can result.

**NOTE 8:** The ISO Standard 5264-2 uses no gap. If a different beating gap is used, report it with test results. This creates non-equivalent results.

9.3.3 Ensure ~~that~~ the beater is clean. Check that the beating conditions are as specified in 6.1.4 and 6.1.5. Transfer the 10% pulp suspension to the beater housing and distribute as evenly as possible over the wall. See that no pulp remains on the bottom of the beater housing within an area corresponding to the cross section of the roll or on the overhang.

9.3.4 Lower the beater roll into the housing and press the cover into position.

9.3.5 Set the beater housing rotating so the pulp is slung against the housing wall and then start the roll. When both elements have attained full speed, gradually apply the required beating pressure, over a 4-s interval (see 6.1.5) using the roll lever arms. Simultaneously start the revolution counter.

**CAUTION:** When beating for a higher number of revolutions, the temperature of the beating elements may increase. If necessary, cool the beating elements with water to bring the temperature within the specified range before the next beating.

9.3.6 After the required number of revolutions of the roll, discontinue beating by disengaging the roll lever arm. Shut off both the motors; center the roll. Lift the roll and housing cover. Transfer all pulp to a 2000-mL beaker

or directly to the disintegrator pot (2000 mL). Rinse the beater with water and add to the beaker/disintegrator pot making sure stock and water do not exceed 2000 mL.

**NOTE 9:** After beating, clean the mill thoroughly with water and, if necessary, pitch solvent.

9.3.7 Pour stock into disintegrator pot, if not already there. Dilute the stock with distilled water to 2000 ± 25 mL disintegrate for 10,000 revolutions.

9.3.8 The pulp is now ready for freeness determination in accordance with TAPPI T 227 “Freeness of Pulp,” and for making and testing of handsheets in accordance with T 205 and T 220.

**NOTE 10:** PFI mills and other laboratory beaters may affect the curl of fibers more than refiners in mills. This may be a source for differences in physical properties between PFI mill and mill refined samples.

## 10. Report

Report test results as specified in the appropriate test method including the number of beating revolutions.

## 11. Precision

11.1 *Repeatability.* PFI mills which have been calibrated and maintained by the prescribed procedure should be capable of providing results within the limits ( $2 \times$  standard deviation shown in Table 1). Data provided by FPInnovations based on PAPTAC Standard C.7. PFI mill which used a 0.2 mm gap between the roll and housing for eastern unbleached kraft pulp; 18 replications with bronze tackle; 17 replications with stainless steel tackle.

11.2 *Reproducibility.* Reproducibility data for the PFI mill as a standard practice is not required.

## 12. Keywords

Beaters, Beating, Revolutions, Laboratory beating, Laboratory refining, PFI mill, Pulp

## 13. Additional information

13.1 Effective date of issue: To Be Assigned

13.2 It is recommended that if a different process pulp is to be processed in the mill, e.g., sulfite followed by kraft, or if a different species of pulp, e.g., hemlock followed by pine, that a minimum of three samples be beaten to 15,000 revolutions each prior to beating a sample for physical testing.

13.3 A normal beater evaluation with the PFI mill should consist of an unbeaten specimen and at least four points to approximately 300 mL CSF.

13.3.1 To establish the beating rate for a pulp specimen, make one or two preliminary runs to determine the freeness/revolutions relationship.

13.3.2 The following beating schedules have been used to reduce specimens to 300-400 mL CSF: softwood kraft pulp, 10,000 revolutions with points at 0, 2500, 5000, 7500, and 10,000 revolutions; hardwood kraft pulp, 5,000 revolutions.

**Table 1.** Repeatability of unbleached eastern softwood kraft pulp (limits are twice the standard deviation)

Revolution	CSF, mLcm <sup>3</sup> /g	Bulk (1 ply), kPa•m <sup>2</sup> /g	Burst index, mN•m <sup>2</sup> /g	Tear index, km	Breaking length,
3000	599 ± 15	1.65 ± 0.08	6.84 ± 0.42	14.78 ± 1.29	9.32 ± 0.66
5000	534 ± 21	1.60 ± 0.05	8.17 ± 0.30	12.85 ± 0.68	10.62 ± 0.69
10,000	356 ± 35	1.54 ± 0.06	9.53 ± 0.31	11.22 ± 0.82	11.86 ± 0.69
15,000	220 ± 35	1.51 ± 0.105	10.15 ± 0.34	10.72 ± 0.49	12.50 ± 0.77

13.4 It is recommended that the standard pulp bale be acquired and used to make periodic checks on the performance of the beater. A statistical control chart (3) can be drafted to display the current performance of the beater.

13.5 Related methods: Scandinavian, SCAN C24; Canadian, PAPTAC C.7, PPRIC PB-6; Australian AS/NZS 1301.2095; International Organization for Standardization, ISO 5264:2.

13.6 During the 2008 revision, the method was revised to improve the organization of its content. No technical changes were made that affect the results of the method. The data and units used in the reproducibility section were changed to reflect current materials and practices at FPIinnovations.

13.7 The Significance section was changed in the 2015 2014 revision. All other changes were editorial.

## Literature cited

1. Stephansen, E., "Beating of Cellulose," *Norsk Skog*, 2:207 (1948) (in English).
2. Nomogram by W. H. Lawford in Hughes, F. T., "The Laboratory Processing of Pulp in Small Beaters," Technical Paper T 391-5, *Pulp and Paper Mag. Can.* 69 (21): 86 (Nov. 1, 1968).
3. American Society for Testing and Materials, D1193-99 Standard Specification for Reagent Water..
4. Pulp and Paper Technical Association of Canada, Standard C.7, Laboratory Beating of Pulp (PFI Mill Method).

## References

Davies, O.L., "Statistical Methods in Research and Production," Hafner Publishing Co., New York, New York, 1961

## Appendix A. Additional care and maintenance of the PFI mill

- A.1 *Static adjustment of the beating gap (4)*
  - A.1.1 Before starting this procedure, make sure that the power is locked off to the PFI mill.
  - A.1.2 With the power off and the housing cover in the upper holding position, pivot the roll over the housing until the axial center lines of the beating elements coincide.
  - A.1.3 Lower the roll into the housing by turning the handwheel. To verify that there is an existing clearance between the roll and housing, engage the roll against the housing wall by moving the weight lever from its neutral position to the vertical position.
  - A.1.4 By hand, slowly turn the roll timing belt, and if the housing rotates along with the roll, disengage the roll by means of the lever arm, and turn the Vernier screw clockwise sufficiently to ensure a clearance. Each division on the Vernier screw collar is equal to a gap of 0.05 mm between the heating elements.

**NOTE A.1:** Use extreme caution in adjusting the zero clearance to avoid undue damage to the roll bars and housing surfaces. Zeroing with the motors driving the roll and/or housing (dynamic zeroing) should not be done as this can cause damage to the rolls and housing surfaces.

A.1.5 To statically adjust the zero clearance, engage the roll toward the housing wall by operating the weight lever arm. With a permanent marking pen, make a reference mark on the front of the beater housing and use it as the starting position when adjusting the beating gap.

A.1.6 While turning the roll timing belt by hand, turn the Vernier screw counterclockwise until the roll can be heard to just make contact with the wall of the housing unit without causing it to rotate. Using the reference mark as a guide, turn the housing 90° three times, checking the zero clearance each time as previously described.

A.1.7 Disengage the roll by returning the weight level arm to its original horizontal position, then set and lock at zero the graduated collar on the Vernier screw. Carefully turn the Vernier screw clockwise to exactly 4 scale divisions. This will give a beating gap of 0.2 mm. Raise the roll and bedplate cover by means of the handwheel and swing to the locked position.

*Your comments and suggestions on this procedure are earnestly requested and should be sent to the TAPPI Standards Department.*

