

**NOTICE: This document is a TAPPI Standard in ballot. Although available for public viewing, it is still under TAPPI's copyright and may not be reproduced or distributed without permission of TAPPI. This document is current under review to be maintained as a TAPPI Standard.**

WI \_\_\_\_\_ 250809.09 \_\_\_\_\_

T \_\_\_\_\_ 277 \_\_\_\_\_

BALLOT NO. \_\_\_\_\_ 03 - SARG \_\_\_\_\_

DRAFT NO. \_\_\_\_\_ 01 \_\_\_\_\_

DATE \_\_\_\_\_ June 9, 2026 \_\_\_\_\_

WORKING GROUP  
CHAIR \_\_\_\_\_ N/A \_\_\_\_\_

SUBJECT  
CATEGORY \_\_\_\_\_ Pulp Properties \_\_\_\_\_

RELATED  
METHODS \_\_\_\_\_ See "Additional Information" \_\_\_\_\_

**CAUTION:**

This Test Method may include safety precautions which are believed to be appropriate at the time of publication of the method. The intent of these is to alert the user of the method to safety issues related to such use. The user is responsible for determining that the safety precautions are complete and are appropriate to their use of the method, and for ensuring that suitable safety practices have not changed since publication of the method. This method may require the use, disposal, or both, of chemicals which may present serious health hazards to humans. Procedures for the handling of such substances are set forth on Safety Data Sheets which must be developed by all manufacturers and importers of potentially hazardous chemicals and maintained by all distributors of potentially hazardous chemicals. Prior to the use of this method, the user must determine whether any of the chemicals to be used or disposed of are potentially hazardous and, if so, must follow strictly the procedures specified by both the manufacturer, as well as local, state, and federal authorities for safe use and disposal of these chemicals.

## **Macro Stickies Content in Pulp: the "Pick-up" Method** *(Five-year review of Standard Practice T 277 sp-21)*

### **1. Scope**

1.1 This standard practice describes removing and preparation of a test specimen that can be analyzed for determining heat-set area and number of macro stickies in a specified amount of pulp screened. The method applies to a wide range of pulps, typically, recycled pulp.

1.2 The standard practice does not quantify content of micro stickies.

### **2. Definitions**

2.1 Stickies are defined as tacky particles, which soften and form a thin film at 90°-95°C (194°-203°F) and 0.8 bar (11.6 psi) in a heated press.

2.2 The standard practice describes a procedure for the collection and removal of the macro stickies content remaining on a slotted screen plate of 0.15 mm (0.006 in.) or 0.10 mm (0.004 in.) when applying controlled screening conditions. Slot width of 0.15 mm is typically used for pulp made from Old Corrugated Container (OCC), whereas 0.10 mm is used for Mixed Office Waste (MOW), Old Newsprint (ONP), Old Magazine (OMG), etc.

2.3 The stickies passing the slotted screen plate under 1 bar are considered micro stickies, and are not quantified in this method.

### 3. Significance

3.1 Stickies testing procedures practiced currently in the industry vary enormously. This procedure provides a consistent format to separate for analysis stickies in a reasonable amount of time and with acceptable precision.

3.2 Stickies present in a papermaking mill system can deposit on wires, felts, dryers, and calender stacks. Therefore, when carried onto the dry end, these stickies frequently cause sheet breaks and downtime for fabric cleaning. This method satisfactorily measures the macro stickies content, thus providing a means to determine the efficiency of stickies removal across various process modules in the recycle process and quantifying the final macro stickies content in the recycled pulp.

3.3 The quantification of stickies allows paper producers and recovered paper traders to identify the contaminant sources and characterize the quality of recovered paper.

### 4. Summary

4.1 Pulp samples are screened using a laboratory screening device. The rejects from the screen are transferred to a black filter paper. A coated paper is placed on top of the filter paper, and then heated and pressed under controlled conditions. Once the coated paper is removed from the filter paper, the coating will be picked up by the stickies and create a contrast on the black filter paper, which readily allows the measurement of area and number of the heat-set stickies with an image analyzer or by hand using the transparent defect size measurement chart. The manufacturer and type of image analyzer and the parameters of measurement are not specified in this standard practice, but an example of an analysis procedure can be found in the appendix of this standard practice.

### 5. Applicable documents

- 5.1 TAPPI T 275 "Screening of Pulp (Somerville-Type Equipment)."
- 5.2 TAPPI T 274 "Laboratory Screening of Pulp (MasterScreen-Type Instrument)."
- 5.3 TAPPI T 278 "Pulp screening (Valley-type screening device)"
- 5.4 TAPPI T 564 "Transparent chart for the estimation of defect size."

### 6. Apparatus

- 6.1 *A laboratory screening device, with 0.15 or 0.10 mm slotted screen plate.*
- 6.2 *Glass-fritted filter (15 cm in diameter).*
- 6.3 *Black wet-strength filter paper (15 cm in diameter). Maximum pore size 25 microns.*
- 6.4 *Coated paper with the following specifications: size 320 mm × 210 mm, plybond resistance of 2 ± 0.5 kN/m per DIN 54516, or 5.5 ± 1.5 kPa per TAPPI T 541 "Internal Bond Strength of Paperboard (z-Direction Tensile)," 70 g/m<sup>2</sup> basis weight of wood-free sized base paper, one-side coated 50 ± 55 g/m<sup>2</sup>, ISO brightness 85 ± 3%.*
- 6.5 *A heated press or sheet making system with heated press with temperature and pressure control. The pressure should be set at 0.8 bar (11.6 psi) and temperature at 90°C.*
- 6.6 *Silicone release liner paper.*
- 6.7 *Water-resistant black felt pen.*
- 6.8 *Filter washing device, as illustrated in Figure 1.*
- 6.9 *Image analysis system with a minimum of optical resolution of 42 microns/pixel (600 ppi) and 256 grey levels. Speck counting starts at 100 μm (0.0078 mm<sup>2</sup>) in diameter.*
- 6.10 *Standard disintegrator, as described in TAPPI T 205 "Forming Handsheets for Physical Tests of Pulp," Appendix A.*

### 7. Sampling

- 7.1 *Sample size.*
  - 7.1.1 An initial sample size of 100 g o.d. is recommended. If a pulp contains high stickies content, the

sample size may be reduced.

7.1.2 In the event the test results do not fulfill the desired statistical requirements per Figures 2 and 3, a second sample with the same sample size is tested and the test numbers are added up until the statistical requirements are fulfilled.

#### 7.2 *Sampling schedule*

7.2.1 Screening of the samples must take place within 24 hours after the samples are collected from the recycle process. When comparing samples, similar elapsed time after sampling has to be applied; otherwise the potential agglomeration of micro stickies into macro stickies will skew the results.

### 8. Testing procedure

#### 8.1 *Disintegration*

8.1.1 Predetermine the pulp consistency according to TAPPI T 240 "Consistency (Concentration) of Pulp Suspensions."

8.1.2 If the debris content is high, disintegrate the sample for 15000 rev. (5 min) at room temperature and 1.0% or less consistency according to TAPPI T 205.

#### 8.2 *Screening*

8.2.1 Screen a pulp sample according to TAPPI T 274, TAPPI T 275 or TAPPI T 278 when using a different screening device. At the end of screening, carefully collect all materials retained on the screen plates and rinse them off into a beaker containing about 250 mL water.

#### 8.3 *Filtering*

8.3.1 Place a filter paper on a glass-fritted funnel. Pour the contents into the 250 mL beaker and apply slight vacuum. In the case of high stickies and debris concentration, the contents in the beaker may be divided into two or more portions in order to prevent overlapping of stickies.-When a pressure screen reject sample collected from a recycling plant is tested, fiber flakes should be picked out before filtering to avoid covering of stickies.

8.3.2 When automated filtration device is used, place a black filter paper on filtering plate before screening.

#### 8.4 *Heat-setting*

8.4.1 After filtering, place a coated paper described in 6.4 on top of the moist black filter paper and then sandwiched between two blotters. The "sandwich" is placed between the lower and upper heated plates of a press. Press the "sandwich" at 0.8 bar (11.6 psi) for 10 minutes at 90°C (194°F).

#### 8.5 *Filter washing*

8.5.1 After heat-setting the stickies, the coated paper is removed from the black filter paper. Flakes, shives, grit, and other non-tacky contaminants are washed off under controlled conditions with a flat spray nozzle for 20 - 25 s (see Fig. 1). The water pressure is about 1 bar (14.5 psi) at a flow rate of 9.6 l/min (2.6 gal/min). Distance between the spray nozzle and the filter paper is approximately 180 mm (7 in.).

#### 8.6 *Post drying*

8.6.1 Cover the washed black filter paper with a silicon paper and is dried in the automated press for 10 min. Temperature and pressure are the same as in 8.4

#### 8.7 *Marking*

8.7.1 Identify the white coating pigments on the black filter paper. If any light colored fibers or other light colored non-tacky contaminants remain on the black filter, a black felt pen is used to dye them black.

8.8 Determine the stickies content by hand or by use of image analysis equipment.

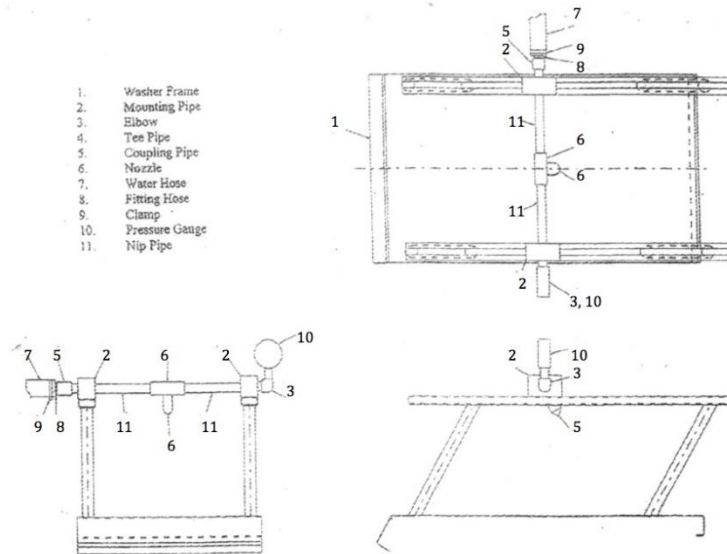

Fig. 1. Spray washer.

## 9. Report

- 9.1 Sampling/testing data.
- 9.2 The elapsed times between sampling, screening and specimen preparation if greater than 24 hours.
- 9.3 Sample ID and pulp specification
- 9.4 Sample size in (g) o.d.
- 9.5 Reference screening device used and size of slotted plate

## 10. Precision

A precision statement is not required for a standard practice.

## 11. Keywords

Stickies, Impurities, Hot melts, Newsprint, Mixed waste papers, Reclaimed fibers, Old corrugated containers, Pulps, Screening, Image analysis

## 12. Additional information

- 12.1 Effective date of issue: To Be Assigned
- 12.2 During the 2013 revision the method was rewritten as a standard practice. This was done to better fit its use as a sample preparation procedure and to permit different automated and non-automated procedures for the stickies "size" estimation content.
- 12.3 *Required sample size*
  - 12.3.1 Figure 2 reveals the required sample size (g) o.d. as a function of the anticipated stickies area ( $\text{mm}^2/\text{g}$ ). The chart is based on statistics and paper mill/pilot plant data.
  - 12.3.2 Figure 3 is solely based on statistics. This chart reveals the required sample size (g) o.d. as a function of the anticipated number of stickies (1/kg).
  - 12.3.3 Applying Fig. 3 will ensure that with an 80% probability, the test results will fall within  $\pm 20\%$  of the true stickies number.

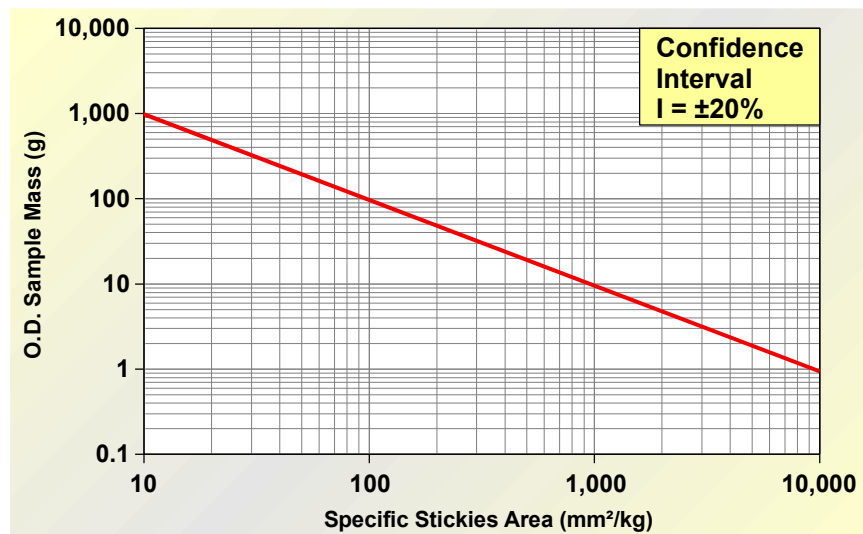

Fig. 2. Minimum sample size as a function of anticipated specific stickies area.

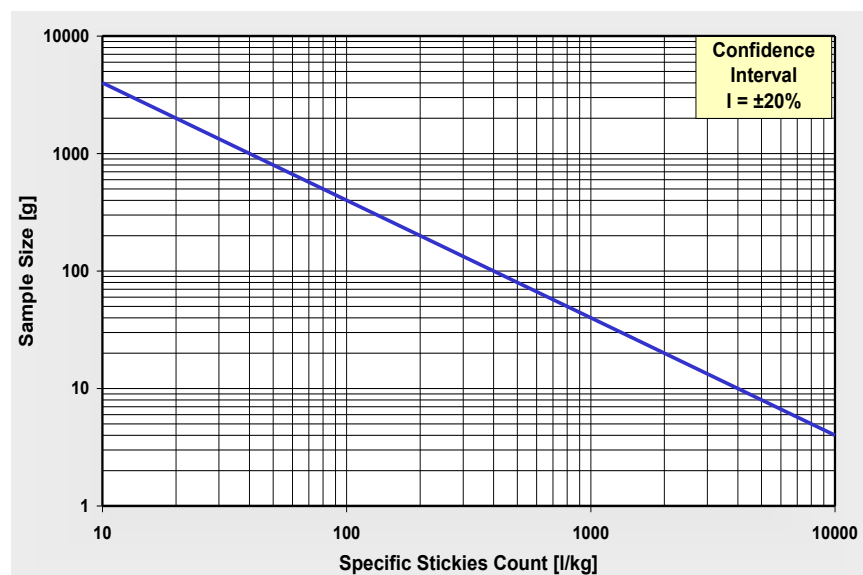

Fig. 3. Minimum sample size as a function of anticipated number of stickies.

#### 12.4 Statistical fundamentals

12.4.1 For a desired 80% probability and a sample size larger than 100 g the mean stickies number  $\mu$  of the complete sample population will fall in the following confidence interval:

$$x - 1.282 \sqrt{\frac{x}{n}} \leq \mu \leq x + 1.282 \sqrt{\frac{x}{n}}$$

where:

$$\begin{aligned} x &= \text{number of stickies (test result)} \\ n &= \text{sample size} \end{aligned}$$

12.4.2 Incorporating the sample size unit (g) and the anticipated specific stickies number  $x$  (stickies/kg o.d. pulp) we utilize equation  $m = 4.11 \times 10^4/x$  to calculate the necessary sample size  $m$  (g) based on a 20% confidence interval.

## References

1. Heise, O., Holik, H., Schabel, S., Cao, B., Kriebel, A., Dehm, J., "A New Stickies Test Method- Statistically Sound And User-Friendly," 1998 TAPPI Product & Process Quality Conference Proceedings, *Tappi Press*, Atlanta, p. 183.
2. Schabel, S., Kriebel A., Dehm, J., Holik, H., "Stickies in weissen und braunen Stoffen - Praxisrelevante Grundlagen zur messtechnischen Erfassung," *Wochenblatt für Papierfabrikation* 125(20):980 (1997).

## Appendix A. Suggested procedure and anticipated results from an automated analysis of stickies areas

### A.1. Image analysis

A.1.1 Follow the manufacturer's instructions to use an image analyzer.

A.1.1.2 Program the image analysis system to start counting at 100 microns (0.0078 mm<sup>2</sup>) in diameter using an inverted video mode. The black filter is backed with a black cardboard to prevent any readings from the cover if a scanner-based system is used.

### A.2. Calculations

A.2.1 Divide the measured macro stickies into ten size classes; each size class states the stickies number and the stickies area. Based on these numbers, the logarithmic area density for each size class is calculated. Further, the total stickies number and area is stated.

Stickies diameter range (µm)	Measured stickies number (-)	Measured stickies area (mm <sup>2</sup> )	Logarithmic area density (mm <sup>2</sup> )
100 - 200			
200 - 300			
300 - 400			
400 - 500			
500 - 600			
600 - 700			
700 - 1000			
1000 - 2000			
2000 - 5000			
> 5000			
TOTALS			

$$\text{Logarithmic Area Density} = 2.303 \times \frac{\text{Measurement Area}}{\text{Size Class Range}} \times \text{Average Size of Class Range}$$

A.2.2 Calculate the specific stickies area using the following equation:

$$S_a = \frac{A}{M}$$

in which,

$S_a$	=	Specific stickies area, mm <sup>2</sup> /kg
$A$	=	Total area of stickies, mm <sup>2</sup>
$M$	=	Total o.d. mass of pulp screened, kg.

A.2.3 Calculate the specific stickies number using the following equation:

$$S_n = N / M$$

in which,

$S_n$	=	Specific stickies number, kg <sup>-1</sup>
$N$	=	Total stickies count
$M$	=	Same as aforementioned

A.2.4 Calculate average stickies size using the following equation:

$$D = S_z / S_x$$

$D$	=	Average stickies size, mm <sup>2</sup>
$S_a$	=	Same as aforementioned
$S_n$	=	Same as aforementioned.

A.2.5 Find out the minimum sample mass required from Figure 2 and 3. If the amount of pulp used for screening is larger than the minimum sample mass, then follow section 10 to report the results. Otherwise, increase the amount of pulp screened until the minimum sample mass is reached.

A.3. Report section covering the analysis procedure

A.3.1 Report the average specific stickies area of two determinations.

A.3.2 Report the average specific stickies number of two determinations.

A.3.3 Report the average stickies size of two determinations

A.3.4 Graphical charting: logarithmic area density vs. stickies size (optional)

A.3.5 Reference screening device used and size of slotted plate

A.4 Example precision statement

A.4.1 For the maximum expected difference between two test results:

Repeatability (within a laboratory) = 28%

Reproducibility (between laboratories) = 101%

A.4.2 The repeatability and reproducibility are in accordance with the definitions specified in TAPPI T 1200 "Interlaboratory Evaluation of Standards to Determine TAPPI Repeatability and Reproducibility."

A.4.3 The repeatability and reproducibility data are based on results obtained from three laboratories on the same sample of old newsprint pulp sample.

A.4.4 Good repeatability and reproducibility can only be achieved with a consistent type of laboratory screening device screen plate and similar operating conditions. For a pulp that contains concentrated debris, precision of the test method will be lowered.

*Your comments and suggestions on this procedure are earnestly requested and should be sent to the TAPPI Standards Department.*

